

5100 Series SATA NAND Flash SSD

**MTFDDAK240T, MTFDDAK480T, MTFDDAK960T,
MTFDDAK1T9T, MTFDDAK3T8T, MTFDDAK7T6T
MTFDDAV240T, MTFDDAV480T, MTFDDAV960T,
MTFDDAV1T9T**

Features

- Micron® 3D TLC NAND Flash
- Three performance/endurance levels
 - ECO
 - PRO
 - MAX
- TCG Enterprise compliant self-encrypting drive (SED)
- SATA 6 Gb/s interface
- ATA modes supported
 - PIO mode 3, 4
 - Multiword DMA mode 0, 1, 2
 - Ultra DMA mode 0, 1, 2, 3, 4, 5, 6
- 512-byte sector size support
- Hot-plug capable (2.5-inch only)
- Native command queuing support with 32-command slot support
- ATA-8 ACS-3 revision 5 command set compliant
- ATA security feature command set and password login support
- Security erase command set: fast and secure erase
- Performance (steady state)¹
 - Sequential 128KB read: Up to 540 MB/s
 - Sequential 128KB write: Up to 520 MB/s
 - Random 4KB read: Up to 93,000 IOPS
 - Random 4KB write: Up to 74,000 IOPS
- Quality of Service²
 - Read/Write (99.9%): 500µs/500µs
 - Read/Write (99.999%): 9ms/5ms
- Endurance⁴: Total bytes written (TBW)
 - ECO: Up to 8,400TB
 - PRO: Up to 17,600TB
 - MAX: Up to 17,600TB
- Reliability
 - MTTF: 3.0 million device hours³
 - Static and dynamic wear leveling
 - Uncorrectable bit error rate (UBER): <1 sector per 10¹⁷ bits read
 - End-to-end data protection
 - Enhanced power-loss data protection with data protection capacitor monitoring
- Self-monitoring, analysis, and reporting technology (SMART) command set
- Capacity⁴ (unformatted): 240GB, 480GB, 960GB, 1920GB, 3840GB, 7680GB
- Mechanical:
 - 2.5-inch x 7.0mm form factor
 - M.2 Type 2280 form factor
- RoHS-compliant package
- Secure field-upgradeable firmware with digitally signed firmware image
- Power consumption: 240GB/480GB: <4.5W(TYP); 960GB: <5.0W(TYP); 1920GB: <5.5W(TYP); 3840GB/7680GB: <6.0W(TYP)
- Operating temperature
 - Commercial (0°C to 70°C)⁵

- Notes:
1. Performance varies by capacity and endurance.
 2. 4KB transfers QD = 1 used for READ/WRITE latency values.
 3. The product achieves a MTTF based on population statistics not relevant to individual units.
 4. 1GB = 1 billion bytes; formatted capacity is less.
 5. As reported by SMART.

Warranty: Contact your Micron sales representative for further information regarding the product, including product warranties.

Part Numbering Information

Micron's 5100 SSD is available in different configurations and densities. The chart below is a comprehensive list of options for the 5100 series devices; not all options listed can be combined to define an offered product. Visit micron.com for a list of valid part numbers.

Figure 1: Part Number Chart

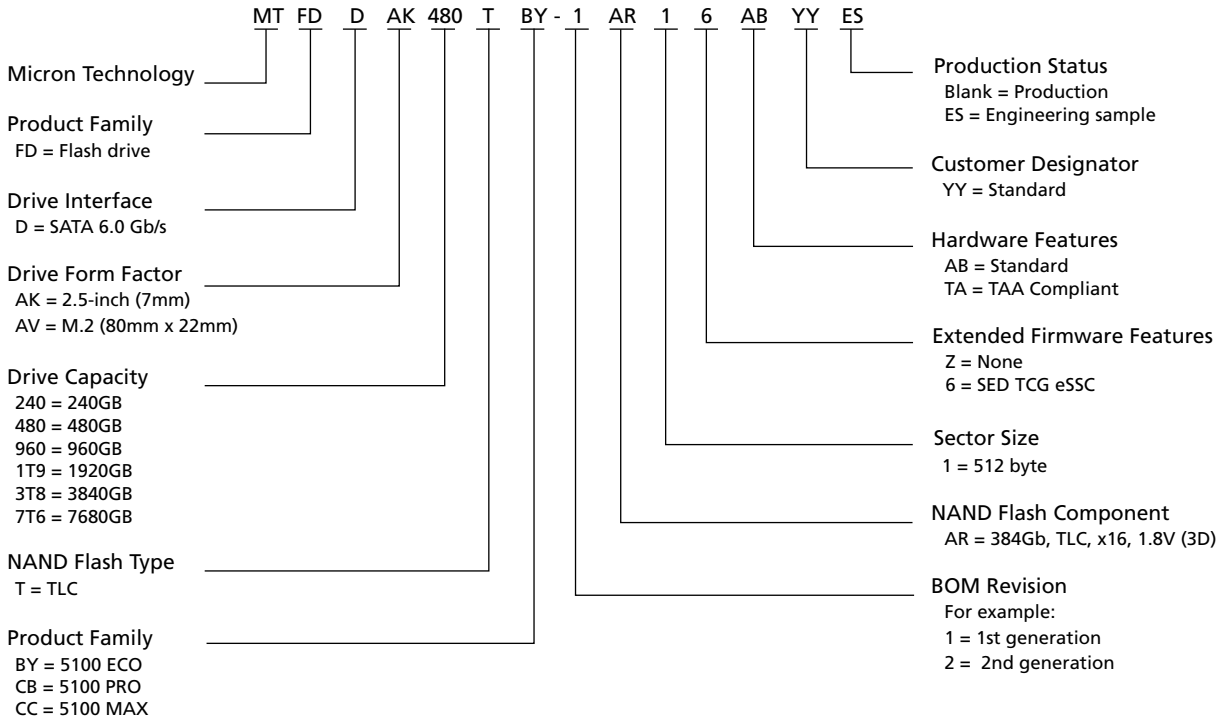

General Description

Micron’s 5100 solid state drive (SSD) uses a single-chip controller with a SATA interface on the system side and four channels of Micron NAND Flash internally. Available in both M.2 and 2.5-inch form factors, the SSD integrates easily in existing storage infrastructures.

The SSD is designed to use the SATA interface efficiently during both READs and WRITEs while delivering bandwidth-focused performance. SSD technology enables enhanced boot times, faster application load times, reduced power consumption and extended reliability.

The self-encrypting drive (SED) features a AES-256 encryption engine, providing hardware-based, secure data encryption, with no loss of SSD performance. This SED follows the TCG Enterprise specification for trusted peripherals. When TCG Enterprise features are not enabled, the device can perform alternate data encryption by invoking the ATA security command set encryption features, to provide full disk encryption (FDE) managed in the host system BIOS. TCG Enterprise and ATA security feature sets cannot be enabled simultaneously.

The data encryption is always running; however, encryption keys are not managed and the data is not secure until either TCG Enterprise or ATA security feature sets are enabled.

Figure 2: Functional Block Diagram

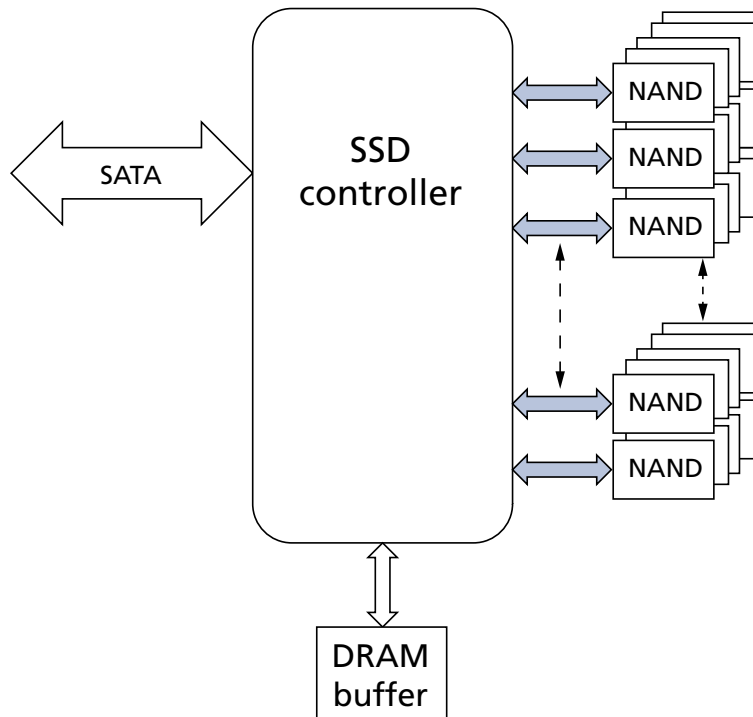

Performance

Measured performance can vary for a number of reasons. The major factors affecting drive performance are the capacity of the drive and the interface/HBA of the host. Additionally, overall system performance can affect the measured drive performance. When comparing drives, it is recommended that all system variables are the same, and only the drive being tested varies.

Performance numbers will vary depending on the host system configuration. Performance is measured using a single drive direct attached (no RAID) to an integrated SATA controller.

Table 1: Drive Performance – ECO 2.5"

Parameter	Capacity					Unit
	480GB	960GB	1920GB	3840GB	7680GB	
Sequential read (128KB transfer)	540	540	540	540	540	MB/s
Sequential write (128KB transfer)	380	520	520	520	520	MB/s
Random read (4KB transfer)	93,000	93,000	93,000	93,000	93,000	IOPS
Random write (4KB transfer)	31,000	28,000	24,000	18,000	9000	IOPS
Random 70/30 R/W (4KB transfer)	49,000	47,000	43,000	36,000	21,000	IOPS
READ latency (99.9%)	500	500	500	500	500	µs
WRITE latency (99.9%)	500	500	500	500	500	µs
READ latency (99.999%)	9.0	9.0	9.0	9.0	9.0	ms
WRITE latency (99.999%)	5.0	5.0	5.0	5.0	5.0	ms

- Notes:
1. Performance measured using FIO with a queue depth of 32 in the steady state region.
 2. 4KB transfers with a queue depth of 1 are used to measure READ/WRITE latency values.
 3. System variations and HBA used will affect measured results.

Table 2: Drive Performance – ECO M.2.

Parameter	Capacity			Unit
	480GB	960GB	1920GB	
Sequential read (128KB transfer)	540	540	540	MB/s
Sequential write (128KB transfer)	380	520	520	MB/s
Random read (4KB transfer)	93,000	93,000	93,000	IOPS
Random write (4KB transfer)	31,000	28,000	24,000	IOPS
Random 70/30 R/W (4KB transfer)	49,000	42,000	39,000	IOPS
READ latency (99.9%)	500	500	500	µs
WRITE latency (99.9%)	500	500	500	µs
READ latency (99.999%)	9.0	9.0	9.0	ms
WRITE latency (99.999%)	5.0	5.0	5.0	ms

- Notes:
1. Performance measured using FIO with a queue depth of 32 in the steady state region.
 2. 4KB transfers with a queue depth of 1 are used to measure READ/WRITE latency values.
 3. System variations and HBA used will affect measured results.

Table 3: Drive Performance – PRO 2.5"

Parameter	Capacity					Unit
	240GB	480GB	960GB	1920GB	3840GB	
Sequential read (128KB transfer)	540	540	540	540	540	MB/s
Sequential write (128KB transfer)	250	410	520	520	520	MB/s
Random read (4KB transfer)	78,000	93,000	93,000	93,000	93,000	IOPS
Random write (4KB transfer)	26,000	43,000	37,000	37,000	30,000	IOPS
Random 70/30 R/W (4KB transfer)	43,000	55,000	54,000	57,000	54,000	IOPS
READ latency (99.9%)	500	500	500	500	500	µs
WRITE latency (99.9%)	500	500	500	500	500	µs
READ latency (99.999%)	9.0	9.0	9.0	9.0	9.0	ms
WRITE latency (99.999%)	5.0	5.0	5.0	5.0	5.0	ms

- Notes:
1. Performance measured using FIO with a queue depth of 32 in the steady state region.
 2. 4KB transfers with a queue depth of 1 are used to measure READ/WRITE latency values.
 3. System variations and HBA used will affect measured results.

Table 4: Drive Performance – PRO M.2.

Parameter	Capacity				Unit
	240GB	480GB	960GB	1920GB	
Sequential read (128KB transfer)	540	540	540	540	MB/s
Sequential write (128KB transfer)	250	410	520	520	MB/s
Random read (4KB transfer)	78,000	93,000	93,000	93,000	IOPS
Random write (4KB transfer)	26,000	43,000	37,000	37,000	IOPS
Random 70/30 R/W (4KB transfer)	43,000	55,000	54,000	57,000	IOPS
READ latency (99.9%)	500	500	500	500	µs
WRITE latency (99.9%)	500	500	500	500	µs
READ latency (99.999%)	9.0	9.0	9.0	9.0	ms
WRITE latency (99.999%)	5.0	5.0	5.0	5.0	ms

- Notes:
1. Performance measured using FIO with a queue depth of 32 in the steady state region.
 2. 4KB transfers with a queue depth of 1 are used to measure READ/WRITE latency values.
 3. System variations and HBA used will affect measured results.

Table 5: Drive Performance – MAX

Parameter	Capacity				Unit
	240GB	480GB	960GB	1920GB	
Sequential read (128KB transfer)	540	540	540	540	MB/s
Sequential write (128KB transfer)	310	460	520	520	MB/s
Random read (4KB transfer)	93,000	93,000	93,000	93,000	IOPS
Random write (4KB transfer)	48,000	74,000	74,000	66,000	IOPS
Random 70/30 R/W (4KB transfer)	57,000	70,000	72,000	70,000	IOPS
READ latency (99.9%)	500	500	500	500	µs
WRITE latency (99.9%)	500	500	500	500	µs
READ latency (99.999%)	9.0	9.0	9.0	9.0	ms
WRITE latency (99.999%)	5.0	5.0	5.0	5.0	ms

- Notes:
1. Performance measured using FIO with a queue depth of 32 in the steady state region.
 2. 4KB transfers with a queue depth of 1 are used to measure READ/WRITE latency values.
 3. System variations and HBA used will affect measured results.

Logical Block Address Configuration

The drive is set to report the number of logical block addresses (LBAs) that will ensure sufficient storage space for the specified capacity. Standard LBA settings, based on the IDEMA standard (LBA1-03), are shown below.

Table 6: Standard LBA Settings – 512-Byte Sector Size

Capacity	Total LBA		Max LBA		User Available Bytes
	Decimal	Hexadecimal	Decimal	Hexadecimal	(Unformatted)
240GB	468,862,128	1BF244B0	468,862,127	1BF244AF	240,057,409,536
480GB	937,703,088	37E436B0	937,703,087	37E436AF	480,103,981,056
960GB	1,875,385,008	6FC81AB0	1,875,385,007	6FC81AAF	960,197,124,096
1920GB	3,750,748,848	DF8FE2B0	3,750,748,847	DF8FE2AF	1,920,383,410,176
3840GB	7,501,476,528	1BF1F72B0	7,501,476,527	1BF1F72AF	3,840,755,982,336
7680GB	15,002,931,888	37E3E92B0	15,002,931,887	37E3E92AF	7,681,501,126,656

Reliability

Micron’s SSDs incorporate advanced technology for defect and error management. They use various combinations of hardware-based error correction algorithms and firmware-based static and dynamic wear-leveling algorithms.

Over the life of the SSD, uncorrectable errors may occur. An uncorrectable error is defined as data that is reported as successfully programmed to the SSD but when it is read out of the SSD, the data differs from what was programmed.

Table 7: Uncorrectable Bit Error Rate

Uncorrectable Bit Error Rate	Operation
<1 sector per 10 ¹⁷ bits	READ

Mean Time to Failure

Mean time to failure (MTTF) for the SSD can be predicted based on the component reliability data using the methods referenced in the Telcordia SR-332 reliability prediction procedures for electronic equipment.

Table 8: MTTF

Capacity	MTTF (Operating Hours)
All capacities	3.0 million

Note: 1. The product achieves a MTTF of 3.0 million hours based on population statistics not relevant to individual units.

Endurance

Endurance for the SSD can be predicted based on the usage conditions applied to the device, the internal NAND component cycles, the write amplification factor, and the wear-leveling efficiency of the drive. Total bytes written measured with 55°C case temperature within the total bytes written values listed in this document. The table below shows the drive lifetime for each SSD capacity based on predefined usage conditions.

Table 9: Drive Lifetime

Capacity	Drive Lifetime (Total Bytes Written)			Unit
	ECO	PRO	MAX	
240GB	–	650	2,200	TB
480GB	450	1,300	4,400	
960GB	900	4,400	8,800	
1920GB	3,200	8,800	17,600	
3840GB	6,400	17,600	–	
7680GB	8,400	–	–	

- Notes:
1. Total bytes written were calculated assuming drive is 100% full (user capacity) and a workload of 100% random, aligned 4KB writes.
 2. 1TB = 1,000,000,000,000 bytes

Electrical Characteristics

Stresses greater than those listed may cause permanent damage to the device. This is a stress rating only, and functional operation of the device at these or any other conditions above those indicated in the operational sections of this specification is not implied. Exposure to absolute maximum rating conditions for extended periods may affect reliability.

Table 10: SATA Power Consumption – 2.5-inch

Capacity	Idle Average	Sequential Write (128KB transfer)	Sequential Read (128KB transfer)
240GB	1.5W	<4.5W	<4.5W
480GB	1.5W	<4.5W	<4.5W
960GB	1.5W	5W	5W
1920GB	1.5W	<5.5W	<5.5W
3840GB	1.5W	<6W	<6W
7680GB	1.5W	6W	6W

- Notes: 1. Data taken at 25°C using a 6 Gb/s SATA interface.
2. Sequential power measured during Iometer with 128KB transfer, RMS average over a 500ms window.

Table 11: SATA Power Consumption – M.2 Type 2280

Capacity	Idle Average	Sequential Write (128KB transfer)	Sequential Read (128KB transfer)
240GB	1.5W	<4.5W	<4.5W
480GB	1.5W	<4.5W	<4.5W
960GB	1.5W	<5W	<5W
1920GB	1.5W	5W	5W

- Notes: 1. Data taken at 25°C using a 6 Gb/s SATA interface.
2. Sequential power measured during Iometer with 128KB transfer, RMS average over a 500ms window.

Table 12: Maximum Ratings

Parameter/Condition	Symbol	Min	Max	Unit
Voltage input (2.5-inch) ¹	V12	10.8	13.2	V
	V5	4.5	5.5	V
Voltage input (M.2)	3V3	3.14	3.46	V
Operating temperature ²	T _C	0	70	°C
Non-operating temperature	–	–40	85	°C
Rate of temperature change	–	–	20	°C/hour
Relative humidity (non-condensing)	–	5	95	%

- Notes: 1. 5V supply required; 12V supply optional
2. Based upon drive temperature reported by SMART

Table 13: Shock and Vibration

Parameter/Condition	Specification
Non-operating shock	1500G/0.5ms
Non-operating vibration	5–800Hz at 3.13 Grms

Device ID

Table 14: Identify Device

See Note 1 for setting definitions

Word	Bit(s)	Setting	Default Value	Description
0	–	–	–	General configuration bit-significant information
	15	F	0b	0 = ATA device
	14–8	X	0000100b	Retired
	7–6	X	01b	Obsolete
	5–3	X	000b	Retired
	2	V	0b	Response incomplete
	1	X	0b	Retired
	0	F	0b	Reserved
1	–	X	3FFFh	Obsolete
2	–	F	C837h	Specific configuration
3	–	X	0010h	Obsolete
4–5	–	X	0000h 0000h	Retired
6	–	X	003Fh	Obsolete
7–8	–	V	0000h 0000h	Reserved for assignment by the CompactFlash™ Association
9	–	X	0000h	Retired
10–19	–	F	Varies	Serial number (20 ASCII characters)
20–22	–	X	0000h 0000h 0000h	Retired/obsolete
23–26	–	F	Varies	Firmware revision (8 ASCII characters)
27–46	–	F	Varies	Model number (40 ASCII characters)
47	15–8	F	80h	80h
	7–0	F	10h	00h = Reserved 01h–FFh = Maximum number of logical sectors that shall be transferred per DRQ data block on READ/WRITE MULTIPLE commands
48	–	–	–	Trusted Computing feature set options
	15	F	0b	Shall be cleared to zero
	14	F	1b	Shall be set to one
	13–1	F	0000000000000b	Reserved for the Trusted Computing Group
	0	F	0b/1b	1 = Trusted Computing feature set is supported This bit will be 1 for TCG drives, otherwise 0

Table 14: Identify Device (Continued)

See Note 1 for setting definitions

Word	Bit(s)	Setting	Default Value	Description
49	–	–	–	Capabilities
	15–14	F	00b	Reserved for the IDENTIFY PACKET DEVICE command
	13	F	1b	1 = Standby timer values as specified in this standard are supported 0 = Standby timer values shall be managed by the device
	12	F	0b	Reserved for the IDENTIFY PACKET DEVICE command
	11	F	1b	1 = IORDY is supported 0 = IORDY may be supported
	10	F	1b	1 = IORDY may be disabled
	9	F	1b	1 = LBA is supported
	8	F	1b	1 = DMA is supported
	7–2	F	000000b	Reserved
	1–0	V	00b	Long physical sector alignment error reporting
50	–	–	–	Capabilities
	15	F	0b	Shall be cleared to zero
	14	F	1b	Shall be set to one
	13–2	F	000000000000b	Reserved
	1	X	0b	Obsolete
	0	F	1b	Shall be set to one to indicate a vendor-specific standby timer value minimum
51–52	–	X	0000h 0000h	Obsolete
53	15–8	V	00h	Free-fall control sensitivity: 00h = Vendor's recommended setting 01h–FFh = Sensitivity level
	7–3	F	00000b	Reserved
	2	F	1b	1 = The fields reported in word 88 are valid 0 = The fields reported in word 88 are not valid
	1	F	1b	1 = The fields reported in words (70:64) are valid 0 = the fields reported in words (70:64) are not valid
	0	X	0b	Obsolete
54–58	–	X	3FFFh 0010h 003Fh FC10h 00FBh	Obsolete

Table 14: Identify Device (Continued)

See Note 1 for setting definitions

Word	Bit(s)	Setting	Default Value	Description
59	15	F	1b	1 = The BLOCK ERASE EXT command is supported
	14	F	1b	1 = The OVERWRITE EXT command is supported
	13	F	1b	1 = The CRYPTO SCRAMBLE EXT command is supported
	12	F	1b	1 = The sanitize feature set is supported
	11	F	1b	1 = The commands allowed during a sanitize operation are specified by ACS-3
	10	F	1b	The SANITIZE ANTIFREEZE LOCK EXT command is supported
	9	F	0b	Reserved
	8	V	1b	1 = Multiple sector settings are valid
	7-0	V	00010000b	xxh = Current setting for number of logical sectors that shall be transferred per DRQ data block on READ/WRITE MULTIPLE commands
60-61	-	F	FFFFh 0FFFh	Total number of user addressable logical sectors for 28-bit commands
62	-	X	0000h	Obsolete
63	15-11	F	00000b	Reserved
	10	V	0b	1 = Multiword DMA mode 2 is selected 0 = Multiword DMA mode 2 is not selected
	9	V	0b	1 = Multiword DMA mode 1 is selected 0 = Multiword DMA mode 1 is not selected
	8	V	0b	1 = Multiword DMA mode 0 is selected 0 = Multiword DMA mode 0 is not selected
	7-3	F	00000b	Reserved
	2	F	1b	1 = Multiword DMA mode 2 and below are supported
	1	F	1b	1 = Multiword DMA mode 1 and below are supported
	0	F	1b	1 = Multiword DMA mode 0 is supported
64	15-2	F	000000000000000b	Reserved
	1	F	1b	PIO mode 4 supported
	0	F	1b	PIO mode 3 supported
65	-	F	0078h	Minimum Multiword DMA transfer cycle time per word Cycle time in nanoseconds
66	-	F	0078h	Manufacturer's recommended Multiword DMA transfer cycle time Cycle time in nanoseconds
67	-	F	0078h	Minimum PIO transfer cycle time without flow control Cycle time in nanoseconds
68	-	F	0078h	Minimum PIO transfer cycle time with IORDY flow control Cycle time in nanoseconds

Table 14: Identify Device (Continued)

See Note 1 for setting definitions

Word	Bit(s)	Setting	Default Value	Description
69	–	F	–	Additional supported
	15	F	0b	Reserved for CFA
	14	F	1b	1 = Deterministic read after trim is supported
	13	F	0b	1 = Long physical sector alignment error reporting control is supported
	12	X	0b	Obsolete
	11	F	1b	1 = READ BUFFER DMA is supported
	10	F	1b	1 = WRITE BUFFER DMA is supported
	9	X	0b	Obsolete
	8	F	1b	1 = DOWNLOAD MICROCODE DMA is supported
	7	F	0b	Reserved for IEEE-1667
	6	F	0b	0 = Optional ATA device 28-bit commands are supported
	5	F	1b	1 = Read zero after trim is supported
	4	F	0b/1b	1 = Device encrypts all user data This bit will be 1 for TCG drives, otherwise 0
	3	F	0b	1 = Extended number of user addressable sectors is supported (words 230 – 233)
	2	F	0b	All write cache is nonvolatile
1–0	–	–	00b Reserved	
70	–	F	0000h	Reserved
71–74	–	F	0000h 0000h 0000h 0000h	Reserved for the IDENTIFY PACKET DEVICE command
75	–	–	–	Queue depth
	15–5	F	00000000000b	Reserved
	4–0	F	11111b	Maximum queue depth - 1

Table 14: Identify Device (Continued)

See Note 1 for setting definitions

Word	Bit(s)	Setting	Default Value	Description
76	–	–	–	Serial ATA capabilities
	15	F	1b	1 = Supports READ LOG DMA EXT as equivalent to READ LOG EXT
	14	F	0b	1 = Supports Device automatic partial to slumber transitions
	13	F	0b	1 = Supports host automatic partial to slumber transitions
	12	F	1b	Native command queuing priority information is supported
	11	F	0b	Unload while NCQ commands are outstanding is supported
	10	F	1b	SATA physical event counter log is supported
	9	F	0b	1 = Receipt of host-initiated interface power management requests is supported
	8	F	1b	Native command queuing is supported
	7–4	F	0000b	Reserved for future Serial ATA signaling speed grades
	3	F	1b	1 = Serial ATA Gen-3 speed (6.0 Gb/s) is supported
	2	F	1b	1 = Serial ATA Gen-2 speed (3.0 Gb/s) is supported
	1	F	1b	1 = Serial ATA Gen-1 speed (1.5 Gb/s) is supported
	0	F	0b	Reserved (set to 0)
77	–	–	–	Serial ATA additional capabilities
	15–7	–	00000000b	Reserved for Serial ATA
	6	F	0b	1 = Supports RECEIVE FPDMA QUEUED and SEND FPDMA QUEUED commands
	5	F	0b	NCQ QUEUE MANAGEMENT command is supported
	4	F	0b	NCQ streaming is supported
	3–1	V	Varies	Coded value indicating current negotiated Serial ATA signal speed
	0	F	0b	Shall be cleared to zero
78	–	–	–	Serial ATA features are supported
	15–8	–	00000000b	Reserved for Serial ATA
	7	F	0b	1 = Device supports NCQ autosense
	6	F	1b	1 = Supports software settings preservation
	5	F	0b	1 = Device supports hardware feature control
	4	F	0b	1 = In-order data delivery is supported
	3	F	0b	1 = Device-initiated interface power management is supported
	2	F	1b	1 = DMA setup auto-activate optimization is supported
	1	F	0b	1 = Non-zero buffer offsets in DMA setup FIS are supported
	0	F	0b	Reserved (set to 0)

Table 14: Identify Device (Continued)

See Note 1 for setting definitions

Word	Bit(s)	Setting	Default Value	Description
79	–	–	–	Serial ATA features are enabled
	15–8	–	00000000b	Reserved for Serial ATA
	7	V	0b	1 = Automatic partial to slumber transitions are enabled
	6	V	1b	1 = Software settings preservation is enabled
	5	V	0b	1 = Hardware feature control is enabled
	4	V	0b	1 = In-order data delivery is enabled
	3	V	0b	1 = Device-initiated interface power management is enabled
	2	V	0b	1 = DMA setup auto-activate optimization is enabled
	1	V	0b	1 = Non-zero buffer offsets in DMA setup FIS is enabled
	0	V	0b	Reserved (set to 0)
80	–	–	–	Major revision number
	15–12	F	0000b	Reserved
	11	F	0b	1 = ATA8-ACS4 is supported
	10	F	1b	1 = ATA8-ACS3 is supported
	9	F	1b	1 = ATA8-ACS2 is supported
	8	F	1b	1 = ATA8-ACS is supported
	7	F	1b	1 = ATA/ATAPI-7 is supported
	6	F	1b	1 = ATA/ATAPI-6 is supported
	5	F	1b	1 = ATA/ATAPI-5 is supported
	4–1	X	1100b	Obsolete
	0	–	0b	Reserved
81	–	F	006Dh	Minor revision number
82	–	–	–	Command and feature sets are supported
	15	X	0b	Obsolete
	14	F	1b	1 = NOP command is supported
	13	F	1b	1 = READ BUFFER command is supported
	12	F	1b	1 = WRITE BUFFER command is supported
	11–10	X	00b	Obsolete
	9	F	0b	1 = DEVICE RESET command is supported
	8–7	X	00b	Obsolete
	6	F	1b	1 = Read look-ahead is supported
	5	F	1b	1 = Write cache is supported
	4	F	0b	Shall be cleared to zero to indicate that the packet feature set is not supported
	3	F	1b	1 = Mandatory power management feature set is supported
	2	X	0b	Obsolete
	1	F	1b	1 = Security feature set is supported
0	F	1b	1 = SMART feature set is supported	

Table 14: Identify Device (Continued)

See Note 1 for setting definitions

Word	Bit(s)	Setting	Default Value	Description
83	–	–	–	Command and feature sets are supported
	15	F	0b	Shall be cleared to zero
	14	F	1b	Shall be set to one
	13	F	1b	1 = FLUSH CACHE EXT command is supported
	12	F	1b	1 = Mandatory FLUSH CACHE command is supported
	11	X	0b	Obsolete
	10	F	1b	1 = 48-bit address feature set is supported
	9–7	X	000b	Obsolete
	6	F	0b	1 = SET FEATURES subcommand required to spin-up after power-up
	5	F	0b	1 = Power-up in standby feature set is supported
	4	X	0b	Obsolete
	3	F	1b	1 = Advanced power management feature set is supported
	2	F	0b	Reserved for CFA
	1	X	0b	Obsolete
	0	F	1b	1 = DOWNLOAD MICROCODE command is supported
84	–	–	–	Command and feature sets are supported
	15	F	0b	Shall be cleared to zero
	14	F	1b	Shall be set to one
	13	F	1b	1 = Idle immediate with unload feature is supported
	12	F	0b	Reserved for technical report INCITS TR-37-2004 (TLC)
	11	F	0b	Reserved for technical report INCITS TR-37-2004 (TLC)
	10–9	X	00b	Obsolete
	8	F	1b	1 = 64-bit word wide name is supported
	7	X	0b	Obsolete
	6	F	1b	1 = WRITE DMA FUA EXT and WRITE MULTIPLE FUA EXT commands are supported
	5	F	1b	1 = General purpose logging feature set is supported
	4	F	0b	1 = Streaming feature set is supported
	3	X	0b	Obsolete
	2	–	0b	Reserved
	1	F	1b	1 = SMART self-test is supported
0	F	1b	1 = SMART error logging is supported	

Table 14: Identify Device (Continued)

See Note 1 for setting definitions

Word	Bit(s)	Setting	Default Value	Description
85	–	–	–	Command and feature sets are supported or enabled
	15	X	0b	Obsolete
	14	F	1b	1 = NOP command is supported
	13	F	1b	1 = READ BUFFER command is supported
	12	F	1b	1 = WRITE BUFFER command is supported
	11–10	X	00b	Obsolete
	9	F	0b	1 = DEVICE RESET command is supported
	8–7	X	00b	Obsolete
	6	V	1b	1 = Read look-ahead is enabled
	5	V	1b	1 = Write cache is enabled
	4	F	0b	Shall be cleared to zero to indicate that the packet feature set is not supported
	3	F	1b	Mandatory power management feature set is supported
	2	X	0b	Obsolete
	1	V	0b	1 = Security feature set is enabled
	0	V	1b	1 = SMART feature set is enabled
86	–	–	–	Command and feature sets are supported or enabled
	15	–	1b	1 = Words 120-119 are valid
	14	X	0b	Reserved
	13	F	1b	1 = FLUSH CACHE EXT command is supported
	12	F	1b	1 = FLUSH CACHE command is supported
	11	X	0b	Obsolete
	10	F	1b	1 = 48-bit address feature set is supported
	9–7	X	000b	Obsolete
	6	F	0b	1 = SET FEATURES subcommand required to spin-up after power-up
	5	V	0b	1 = Power-up in standby feature set is enabled
	4	X	0b	Obsolete
	3	V	1b	1 = Advanced power management feature set is enabled
	2	X	0b	Reserved for CFA
	1	X	0b	Obsolete
	0	F	1b	1 = DOWNLOAD MICROCODE command is supported

Table 14: Identify Device (Continued)

See Note 1 for setting definitions

Word	Bit(s)	Setting	Default Value	Description
87	–	–	–	Command and feature sets are supported or enabled
	15	F	0b	Shall be cleared to zero
	14	F	1b	Shall be set to one
	13	F	1b	1 = IDLE IMMEDIATE with UNLOAD FEATURE is supported
	12–9	X	0000b	Obsolete
	8	F	1b	1 = 64-bit word wide name is supported
	7	X	0b	Obsolete
	6	F	1b	1 = WRITE DMA FUA EXT and WRITE MULTIPLE FUA EXT commands are supported
	5	F	1b	1 = General purpose logging feature set is supported
	4–3	X	00b	Obsolete
	2	V	0b	1 = Media serial number is valid
	1	F	1b	1 = SMART self-test is supported
	0	F	1b	1 = SMART error logging is supported
88	–	–	0b	Ultra DMA modes
	15	–	0b	Reserved
	14	V	0b	1 = Ultra DMA mode 6 is selected 0 = Ultra DMA mode 6 is not selected
	13	V	0b	1 = Ultra DMA mode 5 is selected 0 = Ultra DMA mode 5 is not selected
	12	V	0b	1 = Ultra DMA mode 4 is selected 0 = Ultra DMA mode 4 is not selected
	11	V	0b	1 = Ultra DMA mode 3 is selected 0 = Ultra DMA mode 3 is not selected
	10	V	0b	1 = Ultra DMA mode 2 is selected 0 = Ultra DMA mode 2 is not selected
	9	V	0b	1 = Ultra DMA mode 1 is selected 0 = Ultra DMA mode 1 is not selected
	8	V	0b	1 = Ultra DMA mode 0 is selected 0 = Ultra DMA mode 0 is not selected
	7	–	0b	Reserved
	6	V	1b	1 = Ultra DMA mode 6 and below are supported
	5	V	1b	1 = Ultra DMA mode 5 and below are supported
	4	V	1b	1 = Ultra DMA mode 4 and below are supported
	3	V	1b	1 = Ultra DMA mode 3 and below are supported
	2	V	1b	1 = Ultra DMA mode 2 and below are supported
	1	V	1b	1 = Ultra DMA mode 1 and below are supported
0	V	1b	1 = Ultra DMA mode 0 is supported	
89	–	F	0002h	Time required for security erase unit completion

Table 14: Identify Device (Continued)

See Note 1 for setting definitions

Word	Bit(s)	Setting	Default Value	Description
90	–	F	0002h	Time required for enhanced security erase completion
91	–	V	00FEh	Current advanced power management value
92	–	V	FFFEh	Master password revision code
93	–	–	0000h	Hardware reset results; set to 0000h for SATA devices
94	–	X	0000h	Obsolete
95	–	F	0000h	Stream minimum request size
96	–	V	0000h	Streaming transfer time - DMA
97	–	V	0000h	Streaming access latency - DMA and PIO
98–99	–	F	0000h 0000h	Streaming performance granularity (98-99)
100–103	–	V	Varies by capacity	Maximum user LBA for 48-bit address feature set
104	–	V	0000h	Streaming transfer time - PIO
105	–	F	0008h	Maximum number of 512-byte blocks of LBA range entries per DATA SET MANAGEMENT command
106	–	–	–	Physical sector size/logical sector size
	15	F	0b	Shall be cleared to zero
	14	F	1b	Shall be set to one
	13	F	1b	1 = Device has multiple logical sectors per physical sector
	12	F	0b	1 = Device logical sector longer than 256 Words
	11–4	F	00000000b	Reserved
	3–0	F	0011b	8 logical sectors per physical sector
107	–	F	0000h	Inter-seek delay for ISO-7779 acoustic testing in microseconds
108	15–12	F	0101b	NAA (3-0)
	11–0	–	000000001010b	IEEE OUI (23-12)
109	15–4	F	000001110101b	IEEE OUI (11-0)
	3–0	–	Varies	Unique ID (35-32)
110	–	F	Varies	5-0 unique ID (31-16)
111	–	F	Varies	Unique ID (15-0)
112–115	–	F	0000h 0000h 0000h 0000h	Reserved for 128-bit world wide name extension to 128 bits
116	–	X	0000h	Obsolete
117–118	–	F	0000h 0000h	Words per logical sector

Table 14: Identify Device (Continued)

See Note 1 for setting definitions

Word	Bit(s)	Setting	Default Value	Description
119	–	–	–	Command and feature sets are supported (continued from words 84-82)
	15	F	0b	Shall be cleared to zero
	14	F	1b	Shall be set to one
	13–10	F	0000b	Reserved
	9	F	0b	1 = DSN feature set is supported
	8	F	1b	1 = Accessible maximum address configuration feature set is supported
	7	F	0b	1 = Extended power conditions feature set is supported
	6	F	0b	1 = Sense data reporting feature set is supported
	5	F	0b	1 = Free-fall control feature set is supported
	4	F	1b	1 = DOWNLOAD MICROCODE command with mode 3 supported
	3	F	1b	1 = READ LOG DMA EXT and WRITE LOG DMA EXT commands supported
	2	F	1b	1 = Write uncorrectable EXT command is supported
	1	F	1b	1 = Write-read-verify feature set is supported
	0	X	0b	Obsolete
120	–	–	–	Commands and feature sets are supported or enabled (continued from words 87-85)
	15	–	0b	Shall be cleared to zero
	14	–	1b	Shall be set to one
	13–10	–	0000b	Reserved
	9	–	0b	DSN feature set is enabled
	8	–	0b	Reserved
	7	–	0b	1 = Extended power conditions feature set is enabled
	6	–	0b	1 = Sense data reporting feature set is enabled
	5	–	0b	1 = Free-fall control feature set is enabled
	4	F	1b	1 = The DOWNLOAD MICROCODE command with mode 3 is supported
	3	F	1b	1 = The READ LOG DMA EXT and WRITE LOG DMA EXT commands are supported
	2	F	1b	1 = The WRITE UNCORRECTABLE EXT command is supported
	1	V	0b	1 = The write-read-verify feature set is enabled
	0	X	0b	Obsolete
121–126	–	F	0000h 0000h 0000h 0000h 0000h 0000h	Reserved for expanded supported and enabled settings
127	–	X	0000h	Obsolete

Table 14: Identify Device (Continued)

See Note 1 for setting definitions

Word	Bit(s)	Setting	Default Value	Description
128	–	–	–	Security status
	15–9	F	0000000b	Reserved
	8	V	0b	Master password capability: 0 = High, 1 = Maximum
	7–6	F	00b	Reserved
	5	F	1b	1 = Enhanced security erase is supported
	4	V	0b	1 = Security count is expired
	3	V	0b	1 = Security is frozen
	2	V	0b	1 = Security is locked
	1	V	0b	1 = Security is enabled
	0	F	1b	1 = Security is supported
129–159	–	X	Vendor-specific data	Vendor specific
160–167	–	–	0000h 0000h 0000h 0000h 0000h 0000h 0000h 0000h	Reserved for the CompactFlash Association
168	15–4	F	000h	Reserved
	3–0	F	Varies	Device nominal form factor; 3h = 2.5", 7h = M.2
169	–	–	–	DATA SET MANAGEMENT command support
	15–1	F	000000000000000b	Reserved
170–173	–	F	0000h 0000h 0000h 0000h	Additional product identifier
	–	F	0000h 0000h	Reserved
174–175	–	V	Varies	Current media serial number (60 ASCII characters)
176–205	–	V	Varies	Current media serial number (60 ASCII characters)
206	–	–	–	SCT command transport
	15–12	X	0000b	Vendor-specific
	11–6	F	000000b	Reserved
	5	F	1b	1 = The SCT Data Tables command is supported
	4	F	1b	1 = The SCT Feature Control command is supported
	3	F	0b	1 = The SCT Error Recovery Control command is supported
	2	F	1b	1 = The SCT Write Same command is supported
	1	X	0b	Obsolete
	0	F	1b	1 = The SCT Command Transport is supported
207–208	–	–	0000h 0000h	Reserved

Table 14: Identify Device (Continued)

See Note 1 for setting definitions

Word	Bit(s)	Setting	Default Value	Description
209	–	–	–	Alignment of logical blocks within a larger physical block
	15	F	0b	Shall be cleared to zero
	14	F	1b	Shall be set to one
	13–0	F	00000000000000b	Logical sector offset within the first physical sector where the first logical sector is placed
210–211	–	V	0000h 0000h	Write-read-verify sector count mode 3
212–213	–	F	0000h 0001h	Write-read-verify sector count mode 2
214–216	–	X	0000h 0000h 0000h	Obsolete
217	–	F	0001h	Nominal media rotation rate (non-rotating media)
218	–	–	0000h	Reserved
219	–	X	0000h	Obsolete
220	15–8	F	00h	Reserved
	7–0	V	00h	Write-read-verify feature set current mode
221	–	–	0000h	Reserved
222	–	–	–	Transport major revision number. 0000h or FFFFh = Device does not report version
	15–12	F	0001b	Transport type: 0h = Parallel, 1h = Serial, Eh = PCIe, All others = Reserved
	11–8	–	0000b	Reserved
	7	F	1b	1 = SATA rev 3.2 is supported
	6	F	1b	1 = SATA rev 3.1 is supported
	5	F	1b	1 = SATA rev 3.0 is supported
	4	F	1b	1 = SATA rev 2.6 is supported
	3	F	1b	1 = SATA rev 2.5 is supported
	2	F	1b	1 = SATA II: Extensions are supported
	1	F	1b	1 = SATA rev 1.0a is supported
0	F	1b	1 = ATA8-AST is supported	
223	–	F	0000h	Transport minor revision number
224–229	–	F	0000h 0000h 0000h 0000h 0000h 0000h	Reserved
230–233	–	–	0000h 0000h 0000h 0000h	Extended number of user-addressable sectors
234	–	F	0001h	Minimum number of 512-byte units per DOWNLOAD MICRO-CODE command for mode 3
235	–	F	00FFh	Maximum number of 512-byte units per DOWNLOAD MICRO-CODE command for mode 3
236–242	–	–	0000h 0000h 0000h 0000h 0000h 0000h 0000h	Reserved

Table 14: Identify Device (Continued)

See Note 1 for setting definitions

Word	Bit(s)	Setting	Default Value	Description
243	15	–	0b	Reserved
	14	F	0b/1b	1 = FDE security features supported This bit will be 1 for TCG drives, otherwise 0.
	13–0	–	00000000000000b	Reserved
244–254	–	–	0000h 0000h 0000h 0000h 0000h 0000h 0000h 0000h 0000h 0000h 0000h	
255	–	F	–	Integrity word
	15–8	–	Varies	Checksum
	7–0	–	A5h	Checksum validity indicator

- Note: 1. F = The content of the word is fixed and does not change.
V = The content of the word is variable and may change depending on the state of the device or the commands executed by the device.
X = The content of the word may be fixed or variable.

Commands

Table 15: Supported ATA Command Set

Command Name	Command Code (hex)
AMAC-GET NATIVE MAX ADDRESS EXT	78h/0000h
AMAC-SET ACCESSIBLE MAX ADDRESS EXT	78h/0001h
AMAC-FREEZE ACCESSIBLE MAX ADDRESS EXT	78h/0002h
CHECK POWER MODE	E5h
DATA SET MANAGEMENT – TRIM	06h/0001h
DOWNLOAD MICROCODE	92h
DOWNLOAD MICROCODE DMA	93h
EXECUTE DEVICE DIAGNOSTIC	90h
FLUSH CACHE	E7h
FLUSH CACHE EXT	EAh
IDENTIFY DEVICE	ECh
IDLE	E3h
IDLE IMMEDIATE	E1h
INITIALIZE DEVICE PARAMETERS	91h
NOP	00h
READ BUFFER	E4h
READ BUFFER DMA	E9h
READ DMA (with retry)	C8h
READ DMA EXT	25h
READ FPDMA QUEUED	60h
READ LOG DMA EXT	47h
READ LOG EXT	2Fh
READ MULTIPLE	C4h
READ MULTIPLE EXT	29h
READ SECTOR(S) EXT	24h
READ SECTOR(S) (with retry)	20h
READ VERIFY SECTOR EXT	42h
READ VERIFY SECTOR(S) (with retry)	40h
SANITIZE DEVICE	B4h
SECURITY DISABLE PASSWORD	F6h
SECURITY ERASE PREPARE	F3h
SECURITY ERASE UNIT	F4h
SECURITY FREEZE LOCK	F5h
SECURITY SET PASSWORD	F1h
SECURITY UNLOCK	F2h
SET FEATURES	EFh
SET MULTIPLE MODE	C6h

Table 15: Supported ATA Command Set (Continued)

Command Name	Command Code (hex)
SLEEP	E6h
SMART DISABLE OPERATIONS	B0h/D9h
SMART ENABLE OPERATIONS	B0h/D8h
SMART ENABLE/DISABLE AUTOMATIC OFF-LINE	B0h/DBh
SMART ENABLE/DISABLE AUTOSAVE	B0h/D2h
SMART EXECUTE OFF-LINE IMMEDIATE	B0h/D4h
SMART READ DATA	B0h/D0h
SMART READ DATA ATTRIBUTE THRESHOLDS	B0h/D1h
SMART READ LOG	B0h/D5h
SMART RETURN STATUS	B0h/DAh
SMART SAVE ATTRIBUTE VALUES	B0h/D3h
SMART WRITE LOG	B0h/D6h
STANDBY	E2h
STANDBY IMMEDIATE	E0h
WRITE BUFFER	E8h
WRITE BUFFER DMA	EBh
WRITE DMA (with retry)	CAh
WRITE DMA EXT	35h
WRITE DMA FUA EXT	3Dh
WRITE FPDMA QUEUED	61h
WRITE LOG EXT	3Fh
WRITE LOG DMA EXT	57h
WRITE MULTIPLE	C5h
WRITE MULTIPLE EXT	39h
WRITE MULTIPLE FUA EXT	CEh
WRITE SECTOR(S) (with retry)	30h
WRITE SECTOR(S) EXT	34h
WRITE UNCORRECTABLE EXT	45h

Table 16: Additional Command Set for TCG Drives

Command Name	Command Code (hex)
TRUSTED NON-DATA	5Bh
TRUSTED RECEIVE	5Ch
TRUSTED RECEIVE DMA	5Dh
TRUSTED SEND	5Eh
TRUSTED SEND DMA	5Fh

Interface Connectors

2.5-Inch 7mm

Figure 3: 2.5-Inch 7mm SATA Interface Connections

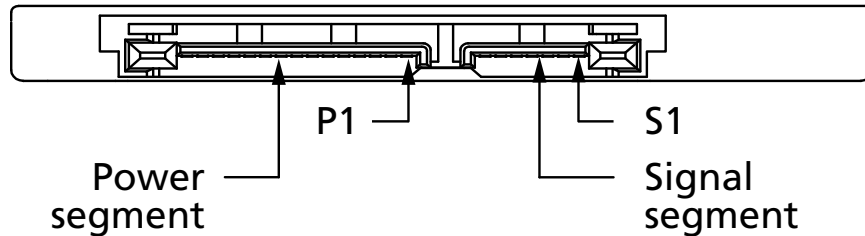

Table 17: Signal Segment Pin Assignments – 2.5-Inch SATA

Signal Name	Type	Description
S1	GND	Ground
S2	A+	Differential signal pair A
S3	A-	
S4	GND	Ground
S5	B-	Differential signal pair B
S6	B+	
S7	GND	Ground

Table 18: Power Segment Pin Assignments – 2.5-Inch SATA

Power Name	Type	Description
P1	Retired	No connect
P2	Retired	No connect
P3	Reserved	No connect
P4	GND	Ground
P5	GND	Ground
P6	GND	Ground
P7	V5	5V power, precharge
P8	V5	5V power
P9	V5	5V power
P10	GND	Ground
P11	DAS	Device activity signal
P12	GND	Ground
P13	V12	12V power
P14	V12	12V power
P15	V12	12V power

M.2 2280

Figure 4: Interface Connections – M.2 Type 2280

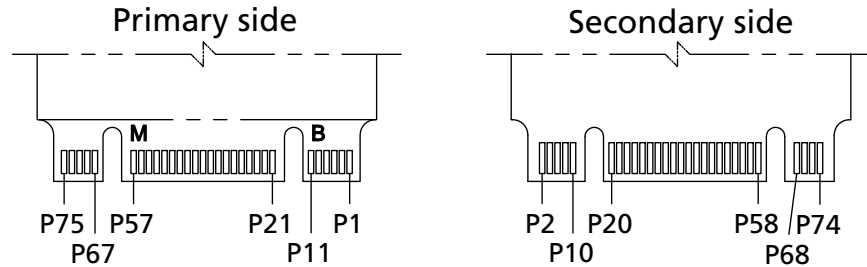

Table 19: Signal Assignments – M.2 Type 2280

Primary Side			Secondary Side		
Pin #	Signal Name	Description	Pin #	Signal Name	Description
1	CONFIG_3	Ground	2	3V3	3.3V
3	GND	Ground	4	3V3	3.3V
5	N/C	No connect	6	N/C	No connect
7	N/C	No connect	8	N/C	No connect
9	N/C	No connect	10	DAS/DSS	Drive activity (host LED)
11	N/C	No connect	Key		
Key			20	N/C	No connect
21	CONFIG_0	Ground	22	N/C	No connect
23	N/C	No connect	24	N/C	No connect
25	N/C	No connect	26	N/C	No connect
27	GND	Ground	28	N/C	No connect
29	N/C	No connect	30	N/C	No connect
31	N/C	No connect	32	N/C	No connect
33	GND	Ground	34	N/C	No connect
35	N/C	No connect	36	N/C	No connect
37	N/C	No connect	38	Reserved	No connect
39	GND	Ground	40	N/C	No connect
41	SATA B+	SATA B differential pair	42	N/C	No connect
43	SATA B-		44	N/C	No connect
45	GND	Ground	46	N/C	No connect
47	SATA A-	SATA A differential pair	48	N/C	No connect
49	SATA A+		50	N/C	No connect
51	GND	Ground	52	N/C	No connect
53	N/C	No connect	54	N/C	No connect
55	N/C	No connect	56	Reserved	Vendor use
57	GND	Ground	58	Reserved	Vendor use

Table 19: Signal Assignments – M.2 Type 2280 (Continued)

Primary Side			Secondary Side		
Pin #	Signal Name	Description	Pin #	Signal Name	Description
Key			Key		
67	N/C	No connect	68	Reserved	No connect
69	CONFIG_1	Ground	70	3V3	3.3V
71	GND	Ground	72	3V3	3.3V
73	GND	Ground	74	3V3	3.3V
75	CONFIG_2	Ground			

Physical Configuration

2.5-Inch 7mm

Product mass: less than 70 grams

Physical dimensions conform to the applicable form factor specifications as listed in the figure below.

Figure 5: 2.5-Inch Package – 7mm

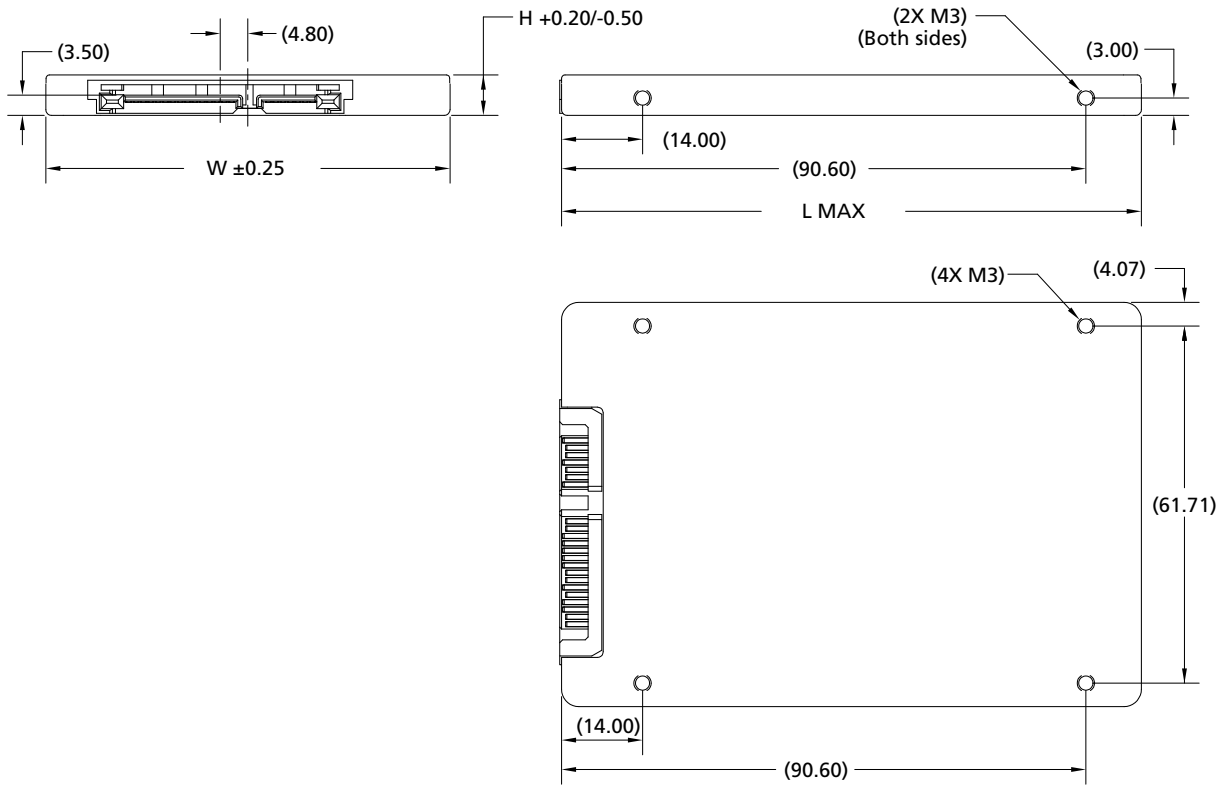

Note: 1. All dimensions are in millimeters.

Table 20: 2.5-Inch Package Dimensions

Capacity (GB)	W	L	H	Unit
240	69.85	100.45	7.00	mm
480				
960				
1920				
3840				
7680				

Note: 1. Dimension values in millimeter per SFF 8201 Rev. 3.3.

M.2 2280

Product mass: less than 10 grams

Physical dimensions conform to the applicable form factor specifications as listed in the figure below.

Figure 6: M.2 Type 2280 Package

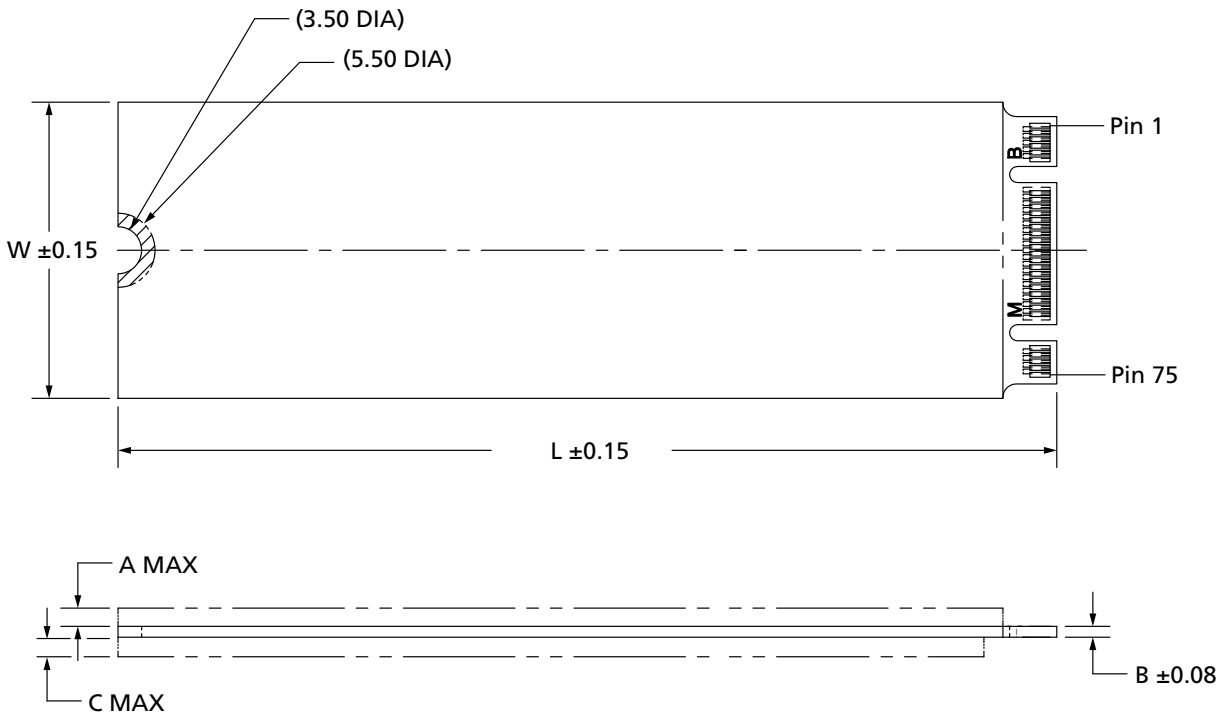

Note: 1. All dimensions are in millimeters.

Table 21: M.2 Type 2280 Package Dimensions

Capacity (GB)	Specification	W	L	A	B	C	Unit
240	D5	22.00	80.00	1.50	0.80	1.50	mm
480							
960							
1920							

Note: 1. Dimension values in millimeter per PCI Express M.2 Specification Rev. 1.0.

Compliance

Micron SSDs comply with the following:

- Micron Green Standard
- Built with sulfur resistant resistors
- CE (Europe): EN 55032 Class B, RoHS
- FCC: CFR Title 47, Part 15 Class B
- UL/cUL: approval to UL-60950-1, 2nd Edition, IEC 60950-1:2005 (2nd Edition); EN 60950-1 (2006) + A11:2009+ A1:2010 + A12:2011 + A2:2013
- BSMI (Taiwan): approval to CNS 13438 Class B and CNS 15663
- RCM (Australia, New Zealand): AS/NZS CISPR32 Class B
- KC RRL (Korea): approval to KN32 Class B, KN 35 Class B

B 급 기기 이 기기는 가정용으로 전자파적합등록을 한 기기로서 주거 (가정용 정보통신기기) 지역에서는 물론 모든지역에서 사용할 수 있습니다.

- W.E.E.E.: compliance with EU WEEE directive 2012/19/EC. Additional obligations may apply to customers who place these products in the markets where WEEE is enforced.
- TUV (Germany): approval to IEC60950/EN60950
- VCCI (Japan): 2015-04 Class B

この装置は、クラス B 情報技術装置です。この装置は、家庭環境で使用することを目的としていますが、この装置がラジオやテレビジョン受信機に近接して使用されると、受信障害を引き起こすことがあります。

取扱説明書に従って正しい取り扱いをして下さい。

VCCI-B

- IC (Canada): ICES-003 Class B
 - This Class B digital apparatus complies with Canadian ICES-003.
 - Cet appareil numérique de la classe B est conforme à la norme NMB-003 du Canada.

FCC Rules

This equipment has been tested and found to comply with the limits for a Class B digital device, pursuant to part 15 of the FCC Rules. These limits are designed to provide reasonable protection against harmful interference in a residential installation. This equipment generates, uses, and can radiate radio frequency energy and, if not installed and used in accordance with the instructions, may cause harmful interference to radio communications. However, there is no guarantee that interference will not occur in a particular installation. If this equipment does cause harmful interference to radio or television reception, which can be determined by turning the equipment off and on, the user is encouraged to try to correct the interference by one or more of the following measures:

- Reorient or relocate the receiving antenna.
- Increase the separation between the equipment and the receiver.
- Connect the equipment into an outlet on a circuit different from that to which the receiver is connected.
- Consult the dealer or an experienced radio/TV technician for help.

References

- Serial ATA: High-speed serialized AT attachment, Serial ATA working group, available at www.sata-io.org
- SATA 3.2 GOLD
- ATA-8 ACS-3 Revision 5
- SFF-8201 Rev. 3.3: For 2.5-Inch mechanical
- Trusted Computing Group (TCG) Enterprise Specification Version 1.00 Revision Final, Revision 3.00 January 10, 2011. Available at www.trustedcomputinggroup.org
- PCI Express M.2 Specification rev 1.0: For M.2 mechanical.
- Trade Agreements Act of 1979 (19 U.S.C. 2501)

Revision History

Rev. C – 08/17

- Increased MTTF rating to 3.0 million hours
- Table 12: Corrected 12V minimum voltage rating
- Updated Compliance section
- Removed FIPS option

Rev. B – 04/17

- Corrected 3.8TB PRO 4KB random write IOPS
- Updated M.2 performance
- Updated ATA Command Set

Rev. A – 12/16

- Initial release

8000 S. Federal Way, P.O. Box 6, Boise, ID 83707-0006, Tel: 208-368-4000
www.micron.com/products/support Sales inquiries: 800-932-4992
Micron and the Micron logo are trademarks of Micron Technology, Inc.
All other trademarks are the property of their respective owners.

This data sheet contains minimum and maximum limits specified over the power supply and temperature range set forth herein. Although considered final, these specifications are subject to change, as further product development and data characterization sometimes occur.

Mouser Electronics

Authorized Distributor

Click to View Pricing, Inventory, Delivery & Lifecycle Information:

Micron Technology:

[MTFDDAK7T6TBY-1AR1ZABYY](#) [MTFDDAK960TBY-1AR16ABYY](#) [MTFDDAK960TBY-1AR1ZABYY](#)
[MTFDDAK960TCB-1AR16ABYY](#) [MTFDDAK960TCB-1AR1ZABYY](#) [MTFDDAK960TCC-1AR16ABYY](#)
[MTFDDAK7T6TDC-1AT1ZABYY](#) [MTFDDAK960TDC-1AT1ZABYY](#) [MTFDDAK960TDD-1AT1ZABYY](#)
[MTFDDAK240TCC-1AR16ABYY](#) [MTFDDAK240TCC-1AR1ZABYY](#) [MTFDDAK1T9TDC-1AT1ZABYY](#)
[MTFDDAK1T9TDD-1AT1ZABYY](#) [MTFDDAK3T8TDC-1AT1ZABYY](#) [MTFDDAK480TDC-1AT1ZABYY](#)
[MTFDDAV960TBY-1AR16ABYY](#) [MTFDDAV960TBY-1AR1ZABYY](#) [MTFDDAV960TCB-1AR16ABYY](#)
[MTFDDAV960TCB-1AR1ZABYY](#) [MTFDDAK240TCB-1AR16ABYY](#) [MTFDDAK240TCB-1AR1ZABYY](#)
[MTFDDAK480TBY-1AR1ZABYY](#) [MTFDDAK480TCB-1AR16ABYY](#) [MTFDDAK480TCB-1AR1ZABYY](#)
[MTFDDAK480TCC-1AR16ABYY](#) [MTFDDAK480TCC-1AR1ZABYY](#) [MTFDDAK7T6TBY-1AR16ABYY](#)
[MTFDDAK3T8TBY-1AR16ABYY](#) [MTFDDAK3T8TBY-1AR1ZABYY](#) [MTFDDAK3T8TCB-1AR16ABYY](#)
[MTFDDAK3T8TCB-1AR1ZABYY](#) [MTFDDAK480TBY-1AR16ABYY](#) [MTFDDAV240TCB-1AR16ABYY](#)
[MTFDDAV240TCB-1AR1ZABYY](#) [MTFDDAV480TBY-1AR16ABYY](#) [MTFDDAV480TBY-1AR1ZABYY](#)
[MTFDDAV480TCB-1AR16ABYY](#) [MTFDDAV480TCB-1AR1ZABYY](#) [MTFDDAK1T9TCC-1AR1ZABYY](#)
[MTFDDAV1T9TBY-1AR16ABYY](#) [MTFDDAV1T9TBY-1AR1ZABYY](#) [MTFDDAV1T9TCB-1AR16ABYY](#)
[MTFDDAV1T9TCB-1AR1ZABYY](#) [MTFDDAK960TCC-1AR1ZABYY](#) [MTFDDAK1T9TBY-1AR16ABYY](#)
[MTFDDAK1T9TBY-1AR1ZABYY](#) [MTFDDAK1T9TCB-1AR16ABYY](#) [MTFDDAK1T9TCB-1AR1ZABYY](#)
[MTFDDAK1T9TCC-1AR16ABYY](#)